

# Charge Ready Program Overview

Last Updated on March 16, 2021

**EXTERNAL**

Energy for What's Ahead<sup>SM</sup>



# Charge Ready Program Offerings

	1 CHARGING INFRASTRUCTURE AND REBATE	2 TURNKEY INSTALLATION	3 NEW CONSTRUCTION REBATE
Objective	Provide <b>make-ready infrastructure</b> for EV charging to non-residential and multifamily sites	Provide <b>full turnkey solution</b> to multifamily properties in DACs	Incentivize multifamily developers to install charging stations at <b>new construction projects</b>
Target Customers	Existing <b>non-residential and multifamily</b> properties	<b>Multifamily properties located in DACs</b>	<b>New construction multifamily properties</b>
Offering	Covers <b>make-ready infrastructure</b> up to EVSE stub-out - AND - <b>EVSE rebate</b> to help offset equipment and installation costs	Covers <b>make-ready infrastructure and EVSE</b> – owned and operated by SCE - OR - Customers can choose to own EVSE and receive a <b>rebate on EVSE, maintenance, and networking</b>	<b>\$3,500 per port</b> to help offset charging station and infrastructure costs
Program Targets	<ul style="list-style-type: none"> <li>~19,500 Level 1 or 2 ports and ~200 DCFC<sup>1</sup> ports</li> <li>50% ports in DAC</li> <li>30% ports at multifamily</li> </ul>	Up to 2,500 Level 1 or 2 ports	<ul style="list-style-type: none"> <li>Up to ~15,000 Level 1 or 2 ports</li> <li>50% ports in DAC</li> </ul>

<sup>1</sup> DCFC program option pending CPUC approval

**EXTERNAL**

# Charge Ready Key Program Requirements

### APPLICANT ROLE

- **Non-residential** SCE customer
- **Own, lease, manage**, or be the customer of record of charging site
- Obtain **consent from property owner** (if applicable)
- Grant **easement rights** to SCE
- Project site must be **located in SCE service area**

### DEPLOYMENT

- **Minimum of four** Level 1 or Level 2 charging ports except New Construction Rebate
- **Minimum of two DCFC** charging ports, if installing DCFC
  - DCFC must be **publicly accessible**
- All charging equipment must be **separately metered** (optional for New Construction Rebate)
- Enroll in a **demand response program**

### EQUIPMENT

- Select from **SCE's Approved Product List (APL)** to qualify for the rebate
- Keep equipment **operational for 10 years**
- Provide **monthly charging data**
- Report **prices charged** to EV drivers

**EXTERNAL**

**Program Overview**

# Charge Ready Program Options

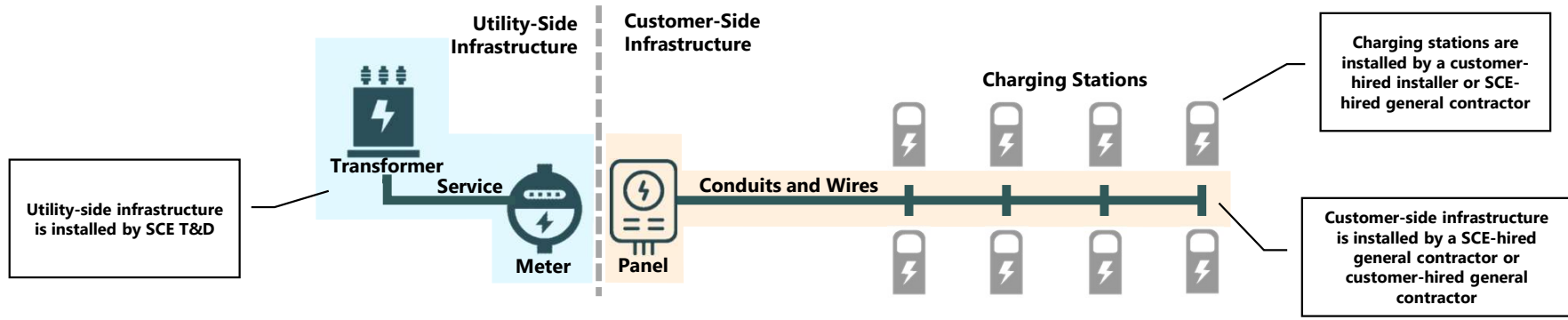

OFFERING S	OPTIONS	AVAILABLE TO	MIN. PORT REQUIREMENT	UTILITY-SIDE INFRASTRUCTURE	CUSTOMER-SIDE INFRASTRUCTURE	EVSE REBATE	INFRASTRUCTURE REBATE	MAINT/NETWORK REBATE
CHARGING INFRA-STRUCTURE & REBATE	<b>1 SCE-Built Infrastructure</b>	Non-residential and multi-family	4+	SCE-installed	SCE-installed	✓	NA	NA
	<b>2 Customer-Built Infrastructure</b>	Non-residential and multi-family choosing to own infrastructure	4+	SCE-installed	Customer-installed	✓	Up to 80% of SCE's cost	NA
	<b>3 Maintenance/Networking Rebate</b>	Multi-family located in DAC / Choosing to own charging stations	4+	SCE-installed	SCE-installed	✓	NA	✓
TURNKEY INSTALLATION	<b>4 Turnkey Installation</b>	Multi-family located in DAC	4+	SCE-installed	SCE-installed	NA	NA	NA
NEW CONSTRUCTION REBATE	<b>5 New Construction Rebate</b>	New multi-family construction	1+	SCE-installed (outside of program)	Customer-installed	Single rebate covering EVSE and infrastructure		NA

**EXTERNAL**